

Addressing challenges to the CWC arising from advances in science and technology: incapacitating chemical agent weapons and “wide area” riot control agent delivery mechanisms

**EU-Non-Proliferation Consortium Conference
4th November 2014**

**Dr Michael Crowley
Project Coordinator
Bradford Non-lethal Weapon Research Project**



Chemical Weapons Convention

The Chemical Weapons Convention (CWC) is a multilateral treaty that prohibits the development, production, stockpiling, transfer and use of chemical weapons **“under any circumstances”**.

In order to fulfill its core objectives to permanently eradicate existing chemical weapons and prevent the development and proliferation of further chemical weapons, the Organisation for the Prohibition of Chemical Weapons (OPCW) must firstly ensure effective monitoring and assessment of advances in those scientific and technological disciplines of relevance to the Convention. Secondly, the information gained from such monitoring activities needs to inform the development of appropriate policy and practice to meet the challenges arising from relevant S&T developments.

This presentation will explore two issue areas where the OPCW is currently failing to adequately meet these challenges, and propose actions to address this dangerous situation.

Chemical Weapons Convention

Article 1:

Each State Party to this Convention undertakes **never under any circumstances:**

(a) To **develop, produce, otherwise acquire, stockpile or retain** chemical weapons, or **transfer, directly or indirectly**, chemical weapons to anyone;

(b) To **use** chemical weapons;

(c) To engage in **any military preparations** to use chemical weapons;

(d) To **assist, encourage or induce, in any way**, anyone to engage in any activity prohibited to a State Party under this Convention. **[Emphasis added]**.

Issue area 1: Incapacitating chemical agents

There is currently no internationally accepted definition for incapacitating chemical agents, as a provisional working description, they can be considered as:

“Substances whose purported intended use is to cause prolonged but non-permanent disability; they include centrally acting agents producing loss of consciousness, sedation, hallucination, incoherence, paralysis, disorientation or other such effects.”

Such ICAs are distinct from riot control agents (RCAs). Whilst RCAs act peripherally on skin, mucous membranes/cause tear formation; incapacitating chemical agents act on key biochemical and physiological systems to produce disabling conditions and in higher concentrations can be fatal.

There is a wide variety of agents that could potentially be utilised as ICAs including anaesthetic agents, skeletal muscle relaxants, opioid analgesics, anxiolytics, antipsychotics, antidepressants and sedative-hypnotic agents, many of which are currently legitimately utilised by the medical or veterinary professions.

Potential candidate ICAs for weaponisation could include a broad range of **pharmaceutical chemicals many of which are legitimately used in medicine**, as well as **bioregulators and toxins**. All three of these chemical classes are covered under the **Chemical Weapons Convention**. In addition, bioregulators and toxins would also fall within the scope of the **Biological and Toxin Weapons Convention**.

Describing incapacitating chemical agents [ICAs]

- **Incapacitating chemical agents: can be considered to be**

“Substances whose purported intended use is to cause prolonged but non-permanent disability; they include centrally acting agents producing loss of consciousness, sedation, hallucination, incoherence, paralysis, disorientation or other such effects.”

[Adapted from 2012 Royal Society Brain Waves study]

- However, the safety margin (the difference between desirable and undesirable effects) may often be very small for a candidate agent, so the effects of ICAs are in fact variable and can include death.

(Bio)chemical threat spectrum

Classical CW	Industrial Pharmaceutical Chemicals	Bioregulators Peptides	Toxins	Genetically Modified BW	Traditional BW
Cyanide Phosgene Mustard Nerve Agents	Fentanyl Carfentanil Remifentanil Etorphine Dexmedetomidine Midazolam	Substance P Neurokinin A	Saxitoxin Ricin Botulinum Toxin	Modified/ Tailored Bacteria Viruses	Bacteria Viruses Rickettsia Anthrax Plague Tularemia
Chemical Weapons Convention			Biological and Toxin Weapons Convention		
Poison				Infect	

Biochemical threat spectrum chart adapted from: Pearson, G. (2002) Relevant Scientific And Technological Developments For The First CWC Review Conference, University of Bradford.

Chemical Weapons Convention

Scope of coverage

Article 2.2 defines a **“toxic chemical”** as:

“...any chemical, regardless of its origin or method of production, which, through chemical action on life processes, can cause death, temporary incapacitation or permanent harm to humans or animals.”

Under Article 2.1 **chemical weapons** include all

(a) *“toxic chemicals and their precursors, **except where intended for purposes not prohibited, as long as the types and quantities are consistent with such purposes.**”*

(b) *munitions and devices specifically designed to cause death or other harm through the toxic properties of those toxic chemicals”* defined in (a)

Under **“purposes not prohibited”** Article 2.9 includes:

(c) *“Military purposes not connected with the use of chemical weapons and not dependent on the use of the toxic properties of chemicals as a **method of warfare**”*

(d) *“**Law enforcement** including domestic riot control purposes,”* [**Emphasis added**].

Regulation of ICAs under CWC, potential use and dangers

- Unlike riot control agents, ICAs are not separately defined under the Chemical Weapons Convention (CWC), but are considered to be toxic chemicals and regulated accordingly. The development, acquisition, stockpiling, transfer or utilisation of such toxic chemicals would be permissible only for “purposes not prohibited”, and only where the “types and quantities” of such toxic chemicals were consistent with such purposes. Consequently, the **employment of ICA weapons in armed conflict is absolutely prohibited under the CWC**. However, there are **differing interpretations as to whether, and in what circumstances, such toxic chemicals could be employed for law enforcement purposes**.
- Proponents of ICA weapons have long promoted their development and use in certain law enforcement scenarios for example in hijackings and armed sieges where hostages have been taken; they have also been raised as a possible tool in a variety of military operations, especially in locations where fighters and civilians are in close proximity or intermingled.
- In contrast, a broad range of observers, including scientific and medical organisations such as the British Medical Association have criticized ICA weapons, contending that the use of these weapons presents potentially grave dangers to health and well-being.
- Other concerns include the dangers of ICA weapons proliferation to both state and non-state actors; their employment to facilitate torture and other human rights violations; the potential for states to use law enforcement ICA weapons development as a cover for covert offensive chemical weapons programs; and the danger of creating a “slippery slope” that could lead to chemical warfare.

ICA weapons: endangering life and health of target population

- *“The agent whereby people could be incapacitated without risk of death in a tactical situation does not exist and is unlikely to in the foreseeable future. In such a situation, it is and will continue to be almost impossible to deliver the right agent to the right people in the right dose without exposing the wrong people, or delivering the wrong dose.”*

British Medical Association Board of Science, The use of drugs as weapons: The concerns and responsibilities of healthcare professionals, London: BMA, May 2007

Other dangers arising from development/use of ICA weapons

- Erosion of norm against weaponization of toxicity
- Proliferation and legitimization by States
- Proliferation to, and misuse by, non-State actors
- Camouflage offensive chemical weapons programmes
- Escalation to lethal chemical weapons
- Use as a lethal force “multiplier”
- Facilitation of torture and other human rights violations
- Militarisation of biology

Past ICA weaponisation and assessing future threats

From the late 1940s onward, military, security, and police bodies and policy makers of certain countries have explored the potential utility of ICA weapons.

States that reportedly conducted research and attempted development of ICA weapons or acquired such weapons at some stage prior to the signing of the Chemical Weapons Convention in 1993 included Albania, China, Iraq, Israel, Apartheid South Africa, the Soviet Union, the United Kingdom, the United States, and Yugoslavia.

For example, the 1960s US development programme led to the production of BZ munitions including the BZ M43 cluster bomb. The US also undertook research and testing of the wide area dispersal of Staphylococcal enterotoxin B (SEB) mounted on American Phantom strike aircraft. There was no use of such ICA weapons in armed conflict and they were later destroyed.

Lessons from History: United States

1960s development of BZ M43 cluster bomb

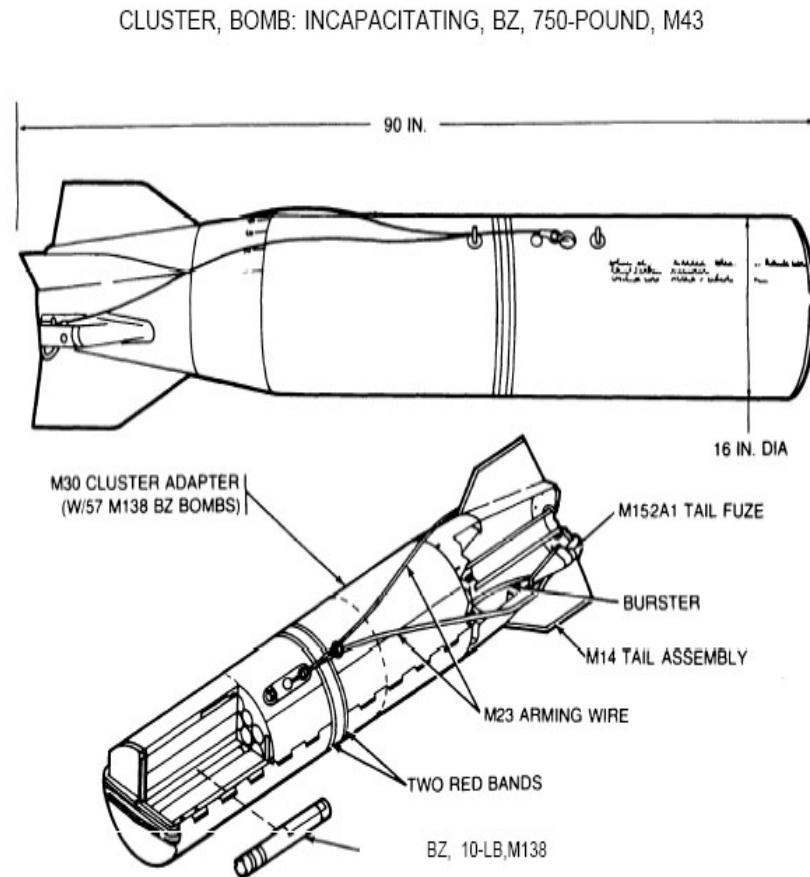

“Use: For aerial delivery of 57 M138 10-pound BZ incapacitating agent bombs on selected targets to temporarily incapacitate enemy personnel. Inhaling BZ causes temporary slowing of mental and physical activity, disorientation, and hallucinations among exposed personnel.”

Technical manual, US Army, equipment data sheets, chemical weapons and munitions TM 43-0001-26-2, Department of the Army, Washington, DC, 29th April 1982

Lessons from History: United States

Development of ICA toxin weapon

In 1968, during DTC Test 68-50, dry-agent spraytanks filled with Agent PG [SEB] mounted on American *Phantom* strike aircraft were released over caged monkeys and other animals at sea off Eniwetok Atoll in the Marshall Islands. The test data reportedly indicated a 30% casualty rate over 2,400 Km² per weapon.

Perry Robinson, J. Bringing the CBW Conventions closer together, *CBW Conventions Bulletin*, issue 80, September 2008

Advances in Science and technology

In the light of previous attempts by a number of States to develop ICA weapons, concerns have grown that the revolutionary changes occurring in a range of relevant chemical and life science disciplines and technologies including neuroscience, medical pharmacology and synthetic biology may be exploited in the weaponisation of incapacitating chemical agents and the development of other chemical weapons.

Advances in the discovery and synthetic production of potential incapacitating chemical agents have occurred in parallel with developments in particle engineering and nanotechnology that could allow the delivery of biologically active chemicals to specific target organs or receptors. The implications of this were highlighted in the [2008 report by the National Research Council on Emerging Cognitive Neuroscience and Related Techniques](#), which warned that nanotechnologies could be used to overcome the blood-brain barrier and thereby “*enable unparalleled access to the brain*”.

The report also highlighted the potential threats resulting from developments in nanotechnologies or gas-phase techniques that allow dispersal of highly potent chemicals over wide areas.

Advances in science and technology: agent development

“In addition to drugs causing calming or unconsciousness, compounds on the horizon with potential as military agents include noradrenaline antagonists such as propranolol to cause selective memory loss, cholecystinin B agonists to cause panic attacks, and substance P agonists to induce depression. The question thus is not so much when these capabilities will arise — because arise they certainly will — but what purposes will those with such capabilities pursue.”

Wheelis, M. and Dando, M. Neurobiology: A case study of the imminent militarization of biology. *International Review of the Red Cross*, September 2005.

Advances in science and technology: agent development

“The explosion of knowledge in neuroscience, bioregulators, receptor research, systems biology and related disciplines is likely to lead to the discovery, amongst others, of new physiologically-active compounds that can selectively interfere with certain regulatory functions in the brain or other organs, and presumably even modulate human behavior in a predictable manner. Some of these new compounds (or selective delivery methods) may well have a profile that could make them attractive as novel candidate chemical warfare agents.”

[Dr Ralf Trapp, 2010 expert meeting on ICAs convened by the International Committee of the Red Cross]

Advances in science and technology: ICA means of delivery

- **Uptake:**
*“New nanotechnologies have allowed molecular conjugation or encapsulation that **may permit unprecedented access [of drugs] to the brain**”... Nanotechnologies can also “exploit existing transport mechanisms to transmit substances into the brain in analogy with the Trojan horse”*
- **Dissemination:**
Gas phase techniques/nanotechnologies: *“pharmacological agents are not used as weapons of mass effect, because their large-scale deployment is impractical” as it is “currently impossible to get an effective dose to a combatant.” However the report states that “**technologies that could be available in the next 20 years would allow dispersal of agents in delivery vehicles that would be analogous to a pharmacological cluster bomb or a land mine.**”*

[National Research Council 2008, Emerging Cognitive Neuroscience and Related Techniques]

**Use of ICA weapon by Russian Federation:
Moscow theatre siege, October 2002**



Development and use of ICA weapons by Russian Federation

- Concerns about ICA weapons were heightened following the use of a presumed derivative of the synthetic opiate analgesic agent, fentanyl, by Russian security forces to free over 900 hostages held by heavily armed Chechen separatists in the Dubrovka theatre in Moscow, in October 2002.
- Although the hostages were released, over 120 died as a result of the direct effects of the agent used or of airway constriction due to their incapacitation. An undetermined, additional number of hostages reportedly suffered long-term damage, or died prematurely in the years after the siege. Russian authorities have to this day refused to give full public details of the ICA weapon used or to provide information on stockpiles of delivery or current development of such weapons. A 2012 paper by researchers at the U.K.'s Defence Science and Technology Laboratory detailed the results of their trace analysis of extracts of clothing and urine from survivors indicating that the aerosol comprised a mixture of two anaesthetics carfentanil and remifentanil.
- There are concerns that the Russian Federation use of an ICA weapon may encourage other States to develop or acquire such weapons.

“The events in Moscow have opened up the potential for this area of research (i.e. incapacitating/immobilizing chemicals) to be explored in much greater depth. It would not be surprising if a number of countries were conducting more detailed and renewed research as a result.”

Stanley, T. Director of the Anaesthesiology Research Laboratories at the University of Utah, 2004

“There is clearly an on-going attraction to “incapacitating chemical agents” but it is not easy to determine the extent to which this has moved along the spectrum from academia and industrial circles into the law enforcement, security and military apparatuses of States.”

International Committee of the Red Cross, Incapacitating chemical agents, implications for international law, report of expert meeting, Montreux, 24th-26th March 2010

Contemporary research

Bradford Nonlethal Weapons Research Project recently conducted a study examining contemporary research into a range of pharmaceutical chemicals potentially applicable to ICA weapons.

[Study available at: <https://biochemsec2030dotorg.files.wordpress.com/2013/08/down-the-slippery-slope-final-web.pdf>]

The study found that Russian researchers have continued work of potential application to the study or development of ICA weapons. This included computer modelling of so-called “calmative” “gas flows” in enclosed spaces, as detailed in a 2009 presentation; and research relating to opiate receptors and their interaction with potential ICAs, detailed in papers from 2005 till 2012. But Russia is not alone.

Our study also highlights the development and marketing by Chinese companies of ICA weapons employing an unknown anaesthetic agent specifically promoted for use by security forces against individuals, and the possession of such weapons in 2011 and 2012 by the Chinese Peoples' Liberation Army. Israel has previously conducted research into ICAs and in 1997 employed an ICA weapon on at least one occasion as an assassination tool. More recently from 2012 there have been unconfirmed and disputed allegations of ICA weapons use by Syrian government forces during the ongoing civil war.

Our study also examined potentially relevant dual-use chemical and life-science research conducted since 1997 in the Czech Republic, India, Iran, the United Kingdom, and the United States.

In certain countries it is difficult to establish the nature and purpose of potentially relevant chemical and life science dual-use research.

Chinese Narcosis gun



“BBQ-901 narcosis gun” on display on State 9616 Plant stand at Asia Pacific China Police Expo 2006, Beijing, China, 24th -27th May 2006
© Robin Ballantyne/Omega Research Foundation

“BBQ-901 tranquiliser gun” being displayed at a People's Liberation Army “open day”, Shek Kong Air Base, Hong Kong, 2nd May 2011.
© Gordon Arthur/King Arthur's Writes.

Statements on ICA weapons development

“I should also like to take this opportunity today to state unequivocally that the UK neither holds, nor is developing, any incapacitating chemical agents for law enforcement. We encourage all other States Parties to state their positions on this question.”

Mr Alister Burt, UK Parliamentary Under Secretary of State for Foreign and Commonwealth Affairs, CWC Third Review Conference, April 2013

“I also wish very clearly and directly to reconfirm that the United States is not developing, producing, stockpiling, or using incapacitating chemical agents.”

Dr Robert Mikulak, US Ambassador to the OPCW, Executive Council May 2013

No formal public statements have been made in OPCW fora to date by **China, Czech Republic, India, Iran, Israel, Russian Federation or Syria** clarifying research activities and rejecting development, stockpiling or use of ICA weapons for law enforcement purposes.

ICA weapons and the OPCW

To date, this issue has not been satisfactorily addressed by the CWC States Parties. No OPCW policy-making organ has made any interpretative statements clarifying whether ICA weapons can legitimately be employed for law enforcement purposes, and if so, in what circumstances and under what constraints.

CWC States Parties are left to interpret the scope and nature of their obligations in this area, with the danger that a “permissive” interpretation may evolve.

In 2013, certain States—including the United Kingdom and United States—formally declared that they are not developing and do not possess ICA weapons. But other States that have conducted research in this area remain silent.

In the light of such concerns Bradford Nonlethal weapons research project developed a range of policy recommendations for addressing this issue.

Recommendations

CWC States Parties, both individually and collectively, should:

- **Initiate a mechanism within the OPCW for States Parties to collectively discuss whether or not the employment of ICA weapons in law enforcement is permissible under the CWC.**
- **Affirm current national practice is to restrict use of toxic chemicals for law enforcement to riot control agents. Where such restriction is not existing policy, States should introduce national moratoria halting initiation or continuation of the development, acquisition, stockpiling, transfer and use of ICA weapons intended for law enforcement purposes.**
- **Reaffirm the existing prohibition on the use of toxic properties of all chemicals as weapons in armed conflict.**
- **Fulfil existing CWC reporting obligations and introduce additional transparency mechanisms.**
- **Utilise existing CWC consultation, investigation and fact-finding mechanisms when activities of potential concern come to their attention, such as reports of the development, acquisition or use of ICA weapons.**

Issue area 2: “wide area” riot control agent means of delivery

Riot control agents (commonly called tear gas) are defined under the CWC, and their use as a method of warfare is expressly prohibited under the Convention. However the Convention permits use of toxic chemicals for “Law enforcement including domestic riot control purposes” [Article 2.9(d)], “as long as the types and quantities are consistent with such purposes” [Article 2.1.(a)]

Consequently, whilst CWC States Parties are prohibited from developing RCA munitions for armed conflict, they may manufacture, acquire and utilise delivery systems to disseminate appropriate types and quantities of RCAs for law enforcement. However, there is continuing ambiguity as to the type and specifications of those means of delivery that are prohibited under the Convention. This ambiguity has potentially dangerous consequences, allowing divergent interpretations, policy and practice amongst States Parties to emerge.

Of particular concern are the implications for regulation of large calibre munitions, delivery systems and dispersal mechanisms that can be utilised for dispersing significant amounts of RCA over wide areas and/or extended distances. Inadequate control of such “wide area” means of delivery has potentially grave consequences, including:

- **Employment in armed conflict** – See historical cases e.g. US/Vietnam; Iran-Iraq.
- **Camouflaging illicit chemical weapons production** – potentially including incapacitant weapons or classic chemical weapons - under guise of RCA law enforcement munitions programmes
- **Proliferation to and misuse by a range of non-State actors**
- **Employment of inherently inappropriate munitions in law enforcement**
- **Misuse to facilitate “large scale” human rights abuses by either State or non-State actors.**

Bradford Non-Lethal Weapons Research Project together with the Omega Research Foundation are conducting ongoing investigations into the development, possession or promotion, since the coming into force of the CWC in 1997, of a range of “wide area” RCA means of delivery, by State or commercial entities in at least 15 countries. [The presentation does not explore any allegations of employment of such means of delivery].

RCAs: Lessons from History

United States use of RCAs in Vietnam war

“Almost every type of weapons delivery system in Viet-Nam had a CS capability, so that CS could swiftly be spread over almost any size of target area, at any range and, if necessary, in close coordination with other forms of firepower.”

Stockholm International Peace Research Institute, The problem of chemical and biological warfare, Volume 1: The rise of CB weapons, 1971, Stockholm, Sweden

*“25 different types of weapon disseminating the irritant agent CS, including heavy munitions ranging up to **155mm artillery shell** and **750-pound aircraft bombs**, were used in Viet Nam. Ultimately **more than 15 million pounds of CS were dispensed in these munitions.**”*

Meselson, M. and Perry Robinson, J. 'Non Lethal' weapons and implementation of the Chemical and Biological Weapons Conventions, 20th Pugwash Workshop Study Group on the implementation of the CBW Conventions, Geneva, Switzerland, 8th-9th November 2003

RCAs: Lessons from History

Iraq's stockpiling and use of RCA munitions

*“Despite the classification of **CS** as riot control agent it was widely used by Iraq for military purposes... CS according to Iraq's declarations was used in conjunction with other chemical agents and conventional ammunition to cause confusion among enemy ground troops during [the] Iran-Iraq war.”*

*“From 1984 until 1985, an unknown number of **“RPG-7”** [rocket propelled] grenades, and over 1,000 82mm [mortars] and 20,000 120mm mortars were filled with CS.”* In addition a *“few hundred”* **BR-250 and AALD-250 bombs** which had a capacity of **60 litres of agent**, and a *“few hundred”* **BR-500 and AALD-500 bombs** which had a **capacity of 120 litres of agent** *“were filled with CS”*.

United Nations Monitoring, Verification and Inspection Commission, Compendium, Iraq Chemical Weapons Programme

Regulation of Riot Control Agents (RCAs) under Chemical Weapons Convention

RCAs defined under Convention as: *“Any chemical not listed in a Schedule, which can produce rapidly in humans sensory irritation or disabling physical effects which disappear within a short time following termination of exposure.”* [Article 2.7]

Convention expressly prohibits the use of *“riot control agents as a method of warfare”*. [Article 1.5]

Convention permits use of toxic chemicals for *“Law enforcement including domestic riot control purposes”* [Article 2.9(d)], *“as long as the types and quantities are consistent with such purposes”* [Article 2.1.(a)]

Afterburner 2000 [United States]



Spray and fogging devices

The **Afterburner 2000** is capable of: “*dispensing many less-than-lethal formulations in a high density aerosol form*”

“standard non-toxic training smoke mixed with irritants such as OC, CS, or Pepper upgrades the capabilities to include: Crowd Control and Civil Unrest, SWAT Teams and Tactical Incursions, Corrections Dept. (Riots / Prisoner Extraction), Less-lethal Terrorist Suppression, Urban Warfare (MOUT / COIN)...” [The required RCAs are provided by the customer]

“A one second trigger burst releases over 1,500 cubic feet of smoke (42.5 cubic meters) with a range greater than 100 feet (30 meters). The standalone version of the Afterburner 2000 expels 50,000 cubic feet (1,416 cubic meters) of smoke on a single charge. The dependent version with high-capacity backpack expels 320,000 cubic feet (9,061 cubic meters) of smoke on a single charger”... “which is approximately a 20 minute deployment.”

[Information taken from documents available on the MSI Delivery Systems, Inc website]

Multiple launchers

A range of multiple launchers have been developed, some intended solely for firing RCA projectiles whilst others are capable of employing a variety of “less lethal” projectiles. Such launchers and associated RCA projectiles can be employed to blanket wide areas, cumulatively delivering significant amounts of RCAs and potentially affecting large numbers of people. They vary in number of projectiles launched, rapidity and mode of fire, range, area coverage as well as in terms of the calibre, weight, and agent fill of the munitions utilised.

BNLWRP and ORF have found examples of launchers capable of firing salvos of multiple 35mm, 38mm, 40mm, 56mm or 64mm RCA projectiles. Projectiles and/or launchers have been developed or promoted by entities in: China, France, India, Russian Federation, South Korea, and the US.

Iron Fist: According to marketing material distributed in 2013 by NonLethal Technologies, when the **IronFist 36 barrel system** is loaded with high capacity 10 inch CS rounds (each with 7 mini-grenades) *“it can rapidly deploy over 250 mini-grenades into the crowd within 2 minutes from... up to 150 metres. Two such configured systems mounted on one armoured vehicle can deploy over 500 CS mini-grenades, or a mix of CS mini-grenades and flashbang-distraction projectiles downrange in that...time...now that is nonlethal firepower!”*

Multi-barrel launchers for “non-lethal” munitions

The IronFist 38mm [United States]

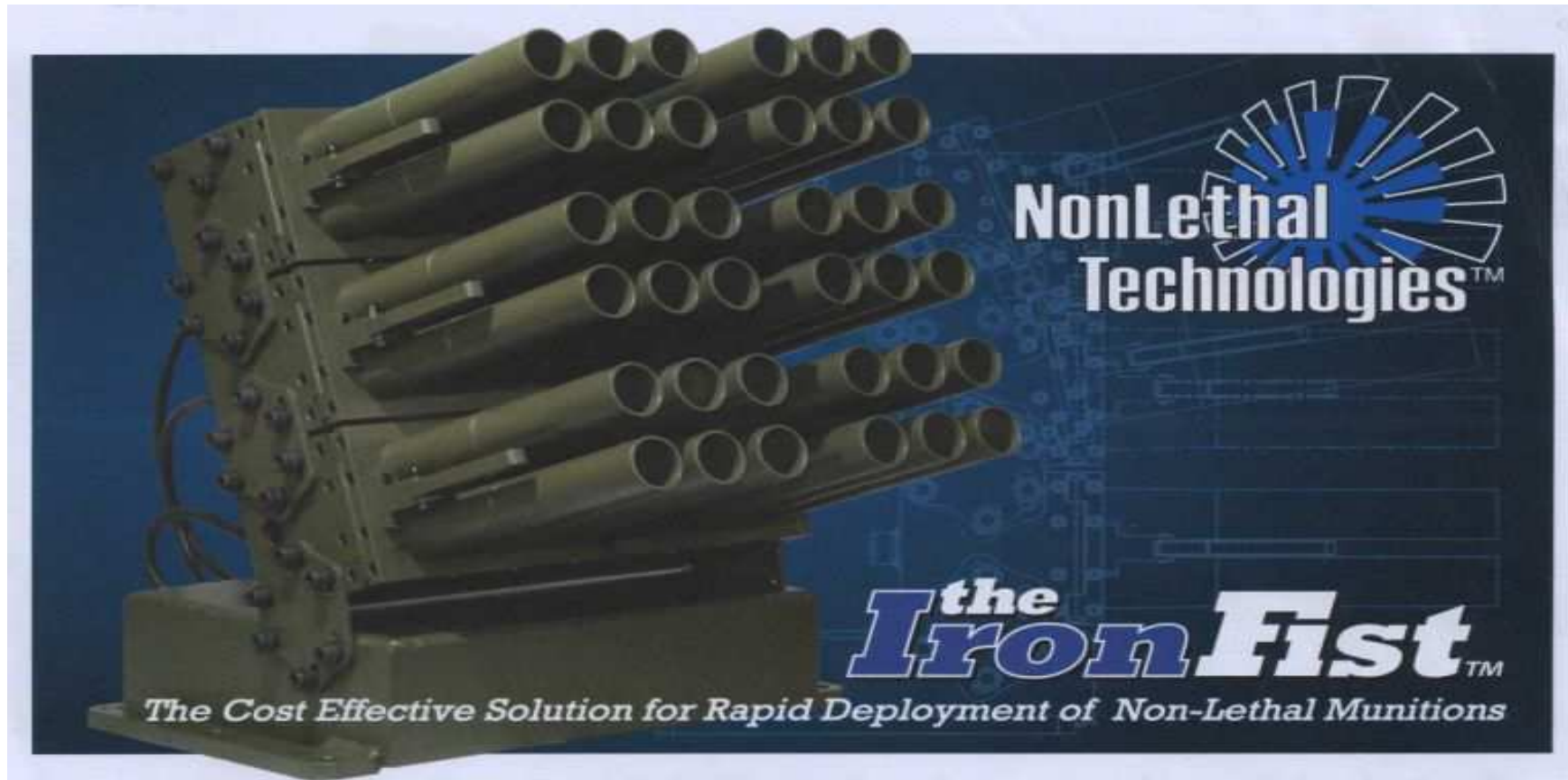

When the **IronFist 36 barrel system** is loaded with high capacity 10 inch CS rounds (each with 7 mini-grenades) *“it can rapidly deploy over 250 mini-grenades into the crowd within 2 minutes from... up to 150 metres. Two such configured systems mounted on one armoured vehicle can deploy over 500 CS mini-grenades, or a mix of CS mini-grenades and flashbang-distractive projectiles downrange in that...time...now that is nonlethal firepower!”*

Automatic Grenade Launchers

30mm grenade [Russian Federation]



A Russian company has reportedly developed a **30-mm grenade** filled with **‘irritant action pyrotechnic composition’**, designed for the **AGS-17 automatic grenade launcher**. The 30mm **munition weighs 350grammes**, and when employed in the AGS-17 has a **maximum range of 1,700 metres** with a **maximum rate of fire of 350-400 rounds per minute**.

[Information in this presentation on Russian RCA munitions taken from 2009 English language version of the 2006 *“Ordnance and munitions”* volume of *“Russia’s Arms and Technologies”*]

Automatic Grenade Launchers

ZLZ94 35mm grenade launcher [China]



The ZLZ94 *“is capable of firing low-propulsion ammunitions continuously.”*

The ammunition is fed by a link feed with 25 rounds available per cartridge box. The **ZLZ94 has a maximum theoretical rate of fire of 58 rounds per minute** and an **effective range of between 100-200 metres**. The company previously stated that it: *“comes into service in People’s Army Garrison Troops in Hong Kong and Macao.”* A second Chinese company promotes the **FKB09 35mm 601 tear gas grenade** which can be fired from the ZLZ94 automatic anti-riot grenade launcher, and has effective **area coverage of more than 300 m²**.

Mortars munition

Bradford Nonlethal Weapons Research Project & Omega Research Foundation uncovered examples of 50mm, 51mm, 60mm, 81/82mm and 120mm RCA mortar munitions promoted by companies from a range of countries including: China, India, Serbia, Russian Federation, Turkey and the United States. Such munitions vary in terms of their calibre, weight, design, material construction, potential payloads, area coverage and range, as well as the purposes for which they have been promoted.

- **60mm, 81/82mm, 120mm cargo mortar shells [Serbia]**

Yugoimport-SDPR's promotional materials have stated that the **Serbian company** developed a range of "*Second generation mortar shells...using modern technical and technological solutions*" which included a number of mortar munitions containing riot control agents. A marketing brochure produced by the company and distributed during 2005 (entitled *Mortars and Mortar Shells*) included information on **60mm, 81/82mm and 120mm M93 cargo mortar shell families**.

According to the company brochure: **each M93 cargo mortar shell family:**

"...consists of one standard cargo shell and three types of submunition:

-HC-smoke composition-based submunition,

-CS-composition – disabling effect submunition,

Incendiary effect submunition."[Emphasis added].

Mortars - CS MKE MOD 251 [Turkey]



- **CS MKE MOD 251 120mm mortar round** manufactured by **Turkish State owned company MKEK**.
- **Weighed 17.34 kg, had maximum range of 8,132 metres and contained CS.**
- According to the Turkish Government: **1,000 CS MKE MOD 251 munitions** were **produced in 1996** prior to Turkey's ratification of the CWC.
- **150 were used for testing** during research and development.
- **Production facility was discontinued after 1997.**
- **Remaining 850 munitions** were subsequently **stored** at the Turkish Armed Forces ammunition destruction facility and **in 2011 they were destroyed.**
- In **February 2011**, Turkey's **OPCW Ambassador** stated that **CS MKE MOD 251 is prohibited under the CWC** and prohibition would extend to other **"mortar ammunition containing tear gas or any other prohibited substance."**

MKEK Tactical CS 120mm mortar round, photographed at IDEF, Ankara, Turkey, 27th- 30 September 2005
(Photo: Robin Ballantyne, Omega Research Foundation).

Mortars

120mm mortar bomb [Russian Federation]

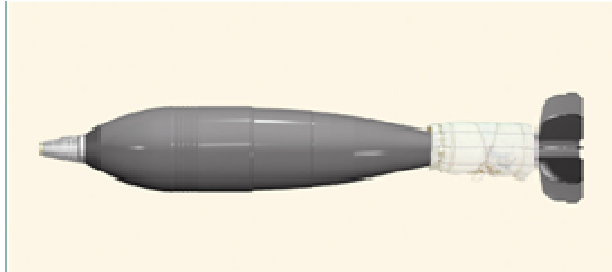

A Russian company has reportedly developed a **120-mm mortar bomb** filled with ‘**irritant-action pyrotechnic composition**’ for Model **1938** and **2B11** mortars, for **2S9**, **2S23** and **2B16** artillery pieces. The mortar bomb weighs **16kg** and has a maximum range of fire of **5.2km** (from 1938 model mortar), **6.8km** (from 2b11 mortar) and **6.6km** (from 2B16, 2S9 and 2S23 guns)

Images of 120mm chemical irritant mortar bomb, 120mm self-propelled gun and 120mm mortar. All images of Russian munitions in this presentation are from www.arsenalrus.com

Large calibre artillery munitions

XM1063 155mm projectile [United States]

Intended functions, to: “*separate combatants from non-combatants; suppress, disperse or engage personnel [and] deny personnel access to, use of, or movement through a particular area, point or facility.*”

Estimates of area coverage: *between 5,000 – 10,000 square metres*

Potential range: *At least 20 km and potentially up to 28km*

Proposed payload: *described as “liquid payload” and “personnel suppression payload”, tested at Army Edgewood Chemical Biological Center.*

According to a July 2008 article in the UK newspaper, *The Guardian*, **testing of the XM1063 was completed successfully in 2007** and it was **due for low-rate production from 2009**. According to *The Guardian*, ARDEC stated “*that the production decision is on hold awaiting further direction from the program manager.*” In a June 2012 *New Scientist* article, Hambling noted that although “*the project is on hold, [it] has been developed by General Dynamics...to the stage of test firings and could be reactivated.*” No further information regarding the current status of the XM1063 research and development programme has been made public by the U.S. Government.

GENERAL DYNAMICS

Ordnance and Tactical Systems



XM1063 – Operational Sequence



- Projectile Fired
- Non-Lethal Payload Release Mechanism Activated



- Non-Lethal Payload Ejected

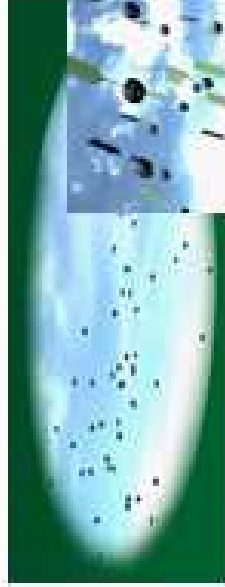

- Non-Lethal Submunitions Dispersed
- KE of Submunitions Minimized

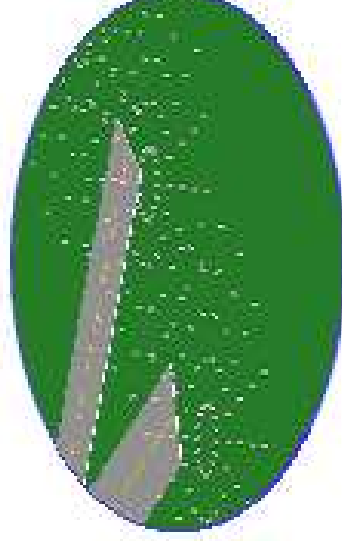

- Non-Lethal Personnel Suppression Effect Delivered Over Target Area
- Base Burner & Projectile Body Delivered to Separate Location

Aerial Delivery Mechanisms

Heliborne RCA munition dispenser [Russian Federation]

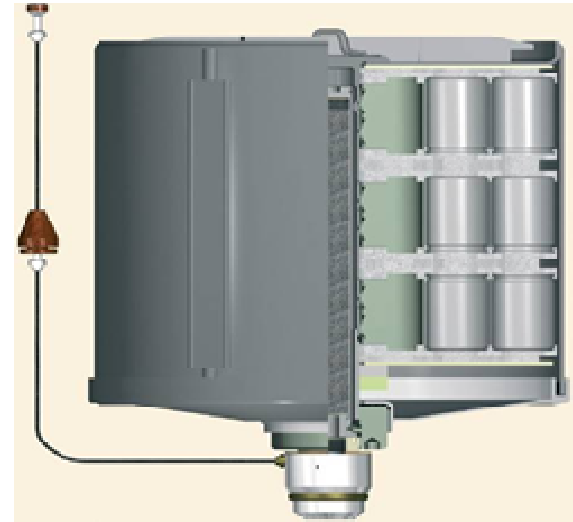

These submunition packages [could be] dispensed singly or all together from helicopters Mi-8MT and Mi-24 (four KMGV dispensers on external hardpoints) at an altitude of 50 to 300m at a flying speed of 150 to 300 km/h. They can also be dropped in the helicopter hovering mode.”

[2009 English language version of the 2006 “Ordnance and munitions” volume of “Russia’s Arms and Technologies]

Aerial Delivery Mechanisms

RCA Cluster Munition [Russian Federation]

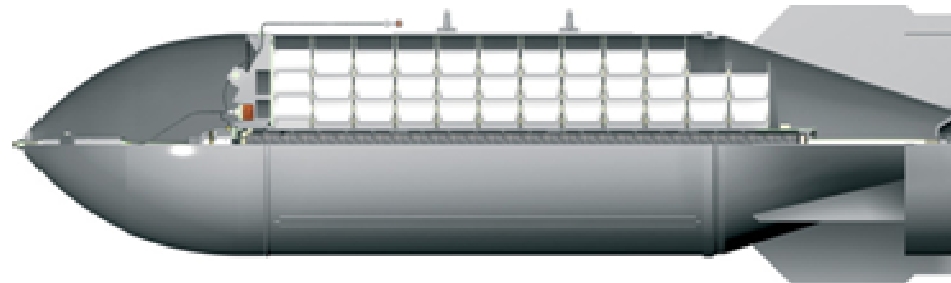

“This cluster bomb has been developed from the standard 500kg cluster bomb packed with smoke submunitions. It [can be] dropped from a fixed-wing or rotary-wing aircraft in an altitude span of 100 to 12,000m at a speed of up to 1,200 km/h...The bomb permits high concentrations of an irritant agent to be attained within a short time.”

[2009 English language version of the 2006 “Ordnance and munitions” volume of “Russia’s Arms and Technologies”]

RIOTBOT unmanned ground vehicle [Spain]



RiotBot employs a mounted PepperBall Tactical Automatic Carbine (TAC 700 launcher) which fires 3 gram PAVA pepper projectile , ***“averages 700 rounds per minute in full automatic mode with up to 60 ft. target accuracy and up to 150 ft. accuracy for saturating an area with pepper.”***

According to Technorobot, RiotBot was developed for a *“wide range of police, military and general security operations...”* ***“some of the scenarios that have been studied for [RiotBot’s] development include: “Riot control... civil order...area denial...boundary defense and intervention ...control point security...surrounding unitrescues ...urban warfare.”***

“Wide area” RCA means of delivery and the OPCW

Certain forms of “wide area” RCA means of delivery may have utility in large scale law enforcement situations provided they meet the CWC “types and quantities” provision and are employed in conformity with human rights standards; however some of these could also be readily misused in armed conflict, thereby breaching the CWC. **Such RCA means of delivery should be stringently regulated to prevent misuse,** [and also to ensure that not adapted for delivery of other toxic agents such as incapacitating chemical agents].

Other forms of “wide area” RCA means of delivery are completely inappropriate for any form of law enforcement, having possible utility only in armed conflict or large scale human rights abuses. Such munitions inherently breach the CWC “types and quantities” provision and/or the prohibition on use of RCAs as a “method of warfare”. [There is also the danger that some could be adapted for delivery of other toxic agents such as incapacitating chemical agents.] **They should be considered to be chemical weapons and treated accordingly.**

Despite the development and promotion of a range of “wide area” RCA means of delivery potentially in conflict with the Convention, none of the OPCW policy making organs have effectively addressed this issue to date.

Recommendations

The relevant policy making organs bodies of the OPCW – namely the Executive Council and the Conference of States Parties – in consultation with the Technical Secretariat should:

- **Develop a process for determining prohibited means of RCA delivery;**
- **Develop a clarificatory document detailing prohibited RCA means of delivery;**
- **Strengthen existing RCA declaration and reporting measures, and explore feasibility and utility of monitoring and verification measures.**
- **States Parties should utilise existing CWC consultation, investigation and fact-finding mechanisms where activities of potential concern come to their attention** such as the reported development, marketing, transfer, stockpiling or use of prohibited means of RCA delivery.

General conclusions: effectively addressing advances in science and technology

The negotiators of the Chemical Weapons Convention were far-sighted enough to build into the treaty, language -notably the General Purpose Criterion - to ensure that it is flexible enough to cover and respond to all likely developments in relevant science and technology. Similarly the OPCW has established a range of mechanisms which can be employed to monitor and respond to science and technological developments of potential concern.

However such safeguards are only as good as the will of the States Parties to employ them. To date, it appears that in the case of incapacitating chemical agent weapons and “wide area” RCA means of delivery, the will to act has not been forthcoming.

If the OPCW does not actively engage with these issues in the near future, there is a danger that an ever growing number of countries will seek to harness advances in relevant scientific disciplines for development programs or may be perceived—rightly or wrongly—of doing so. This, in turn, may convince other States to conduct their own R&D programs or potentially explore an even broader range of chemical agents and delivery mechanisms, with the danger of a consequent spiral of actions and reactions that could weaken the prohibition on chemical weapons.

The forthcoming Conference of States Parties in December provides an appropriate forum for Member States to begin the process of collectively responding to these challenges.